

# **On-line microwave spectrometer**

***I. Renhart***

Belarussian Polytechnical Academy, Microradar  
Company, Belarus

## **Background**

**Measurement of dielectric properties of various materials has recently become an integral part of many technological processes in chemistry, biotechnology and in production of extra pure substances and pharmaceuticals. However, in some cases controlling of these characteristics at one or two frequencies is not quite sufficient. Existing dielectric spectrometers presumably intended for scientific purposes are rather expensive and with probably a few exceptions cannot be used for on-line measurements in industry.**

***The aim of this research was the development of relatively not expensive industrial microwave spectrometers for on-line measurements.***

## Theory of method

Resonator meters of dielectric properties are well known and are widely used for measurements of moisture, density, geometrical dimensions and some other parameters of various technological processes.

The shift in the resonance frequency,  $\Delta f$ , due to insertion of a material with permittivity  $\varepsilon'$  into a resonator, is given by

$$\frac{\Delta f}{f_0} = \frac{f - f_0}{f_0} \approx -\frac{1}{2}(\varepsilon' - 1) \cdot F(V_S, V_0) \quad (1)$$

and the quality factor by:

$$\frac{1}{Q} - \frac{1}{Q_0} \approx \varepsilon'' \cdot F(V_S, V_0) \quad (2)$$

where  $f_0$  is the resonance frequency of the empty resonator,  $f$  is the resonance frequency with the material under test within the sample space of the resonator,  $\varepsilon'$  and  $\varepsilon''$  are real and imaginary permittivities of the material under test, and  $F(V_S, V_0)$  is the coefficient characterising the ratio of the resonator volume to the volume of the material.

For the open  $\lambda/4$  resonator of length  $L$  (Fig.1) the frequency of principle resonance mode,  $f_r$ , is given by

$$f_r = \frac{C_0}{4(L + CC_0Z_0)} \quad (3)$$

where  $C$  is the speed of light in vacuum;  $C_0$  is the fringe capacitance of the central conductor; and  $Z_0$  is the characteristic impedance of the coaxial line.

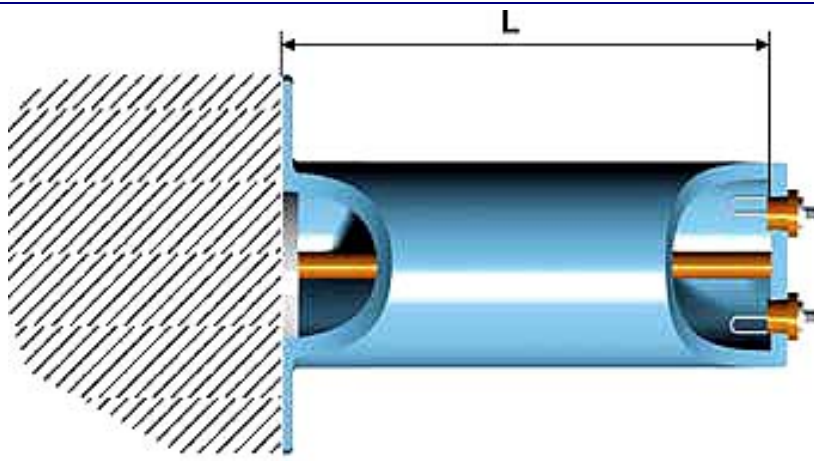

Fig. 1

Resonance frequencies associated with higher order modes can be expressed as follows

$$f_{r_n} = \frac{C_0(2n+1)}{4(L + CC_0Z_0)} \quad (4)$$

If the range of microwave generator frequency sweep is restricted properly than the single resonance peak will always be obtained. And vice versa if one chooses some particular working resonance wavelength than the resonator length must be equal to an odd number of this wavelength quarters.

However, the disadvantage of increasing the resonator length is reduced sensitivity of the sensor to the real part of permittivity of material filling the fringe capacitance,  $C_0$ . This can be realised through the expression

$$\frac{\Delta f}{f_r} = - \frac{CZ_0(E'-1)}{\frac{(2n+1)}{4f_r} - CZ_0} \quad (5)$$

Since the Q-factor of a resonator is given by the ratio of the accumulated energy to the lost energy, it follows that the sensitivity of the sensor to the real and imaginary part of permittivity of the material under test will decrease, with an increase in the resonator volume. In order to improve the sensitivity, the sensor was designed so that the material under test occupies not only the fringe field zone but a certain part of the resonator volume as well (Fig 2). In this case :

$$\frac{\Delta f}{f_r} = - \frac{CZ_0C_0(E'-1) + l(\sqrt{E'} - 1)}{\frac{2n+1}{4f_r}C_0 - CZ_0C_0} \quad (6)$$

where  $l$  is the length of the segment of the resonator coaxial line filled with material.

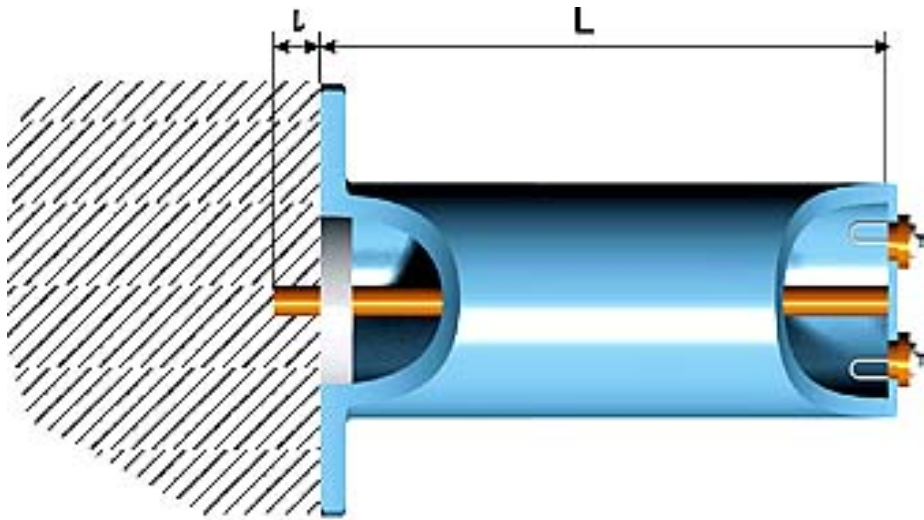

Fig. 2

### Choice of a modelling material

To get broad variations of real and imaginary parts of inductivity the wet adamant was selected as a model material.

In the microwave band, the behaviour of a hydrated powder (from the viewpoint of the dielectric properties) can be described with the sufficient accuracy by a linear approximation. In the framework of this model, the attenuation coefficient  $\alpha$  and the coefficient of propagation of the electromagnetic wave  $\beta$  in a hydrated powder are the linear superposition of the corresponding coefficients for each component:

$$\alpha = \sum_i v_i \alpha_i, \quad \beta = \sum_i v_i \beta_i, \quad (7)$$

where  $v_i$  is a volume content of  $i$ -component.

Using known relations

$$\alpha = \frac{\pi}{\lambda} \frac{E''}{\sqrt{E'}}, \quad \beta = \frac{2\pi}{\lambda} \sqrt{E'}, \quad (8)$$

where  $\lambda$  is a wavelength,  $E=E'-iE''$  is a complex dielectric permittivity, we can obtain next expressions for three-component mixture (material+water+air):

$$E'' = \frac{E''_W}{\sqrt{E'_W}} W \rho \sqrt{E'}$$

$$\sqrt{E'} = W \rho (\sqrt{E'_W} - 1) + (\sqrt{E'_d} - 1) \frac{\rho}{\rho_d} (1 - W) + 1,$$

where  $W$  is a moisture content,  $\rho$  is a density of moisture material,  $E_W=E'_W-iE''_W$  is a dielectric permittivity of water,  $\rho_d$  is a density of dry material,  $E'_d$  is a real part of relative permittivity of dry material with density  $\rho_d$ .

It should be mentioned, however, that these relations are valid only for the single phase water, i.e. for water, which is present in the material in some definite form (either free or bound) and does not change its dielectric properties with variation of moisture. In the majority of cases, and especially in case of low moisture content, this assumption is not valid and therefore, at a given frequency, one must use averaged values of permittivity for calculations through the entire range of moisture.

## Experiment

The results of testing of a spectrometer are shown in Figs.3 and 4. The measurements were made at 25°C.

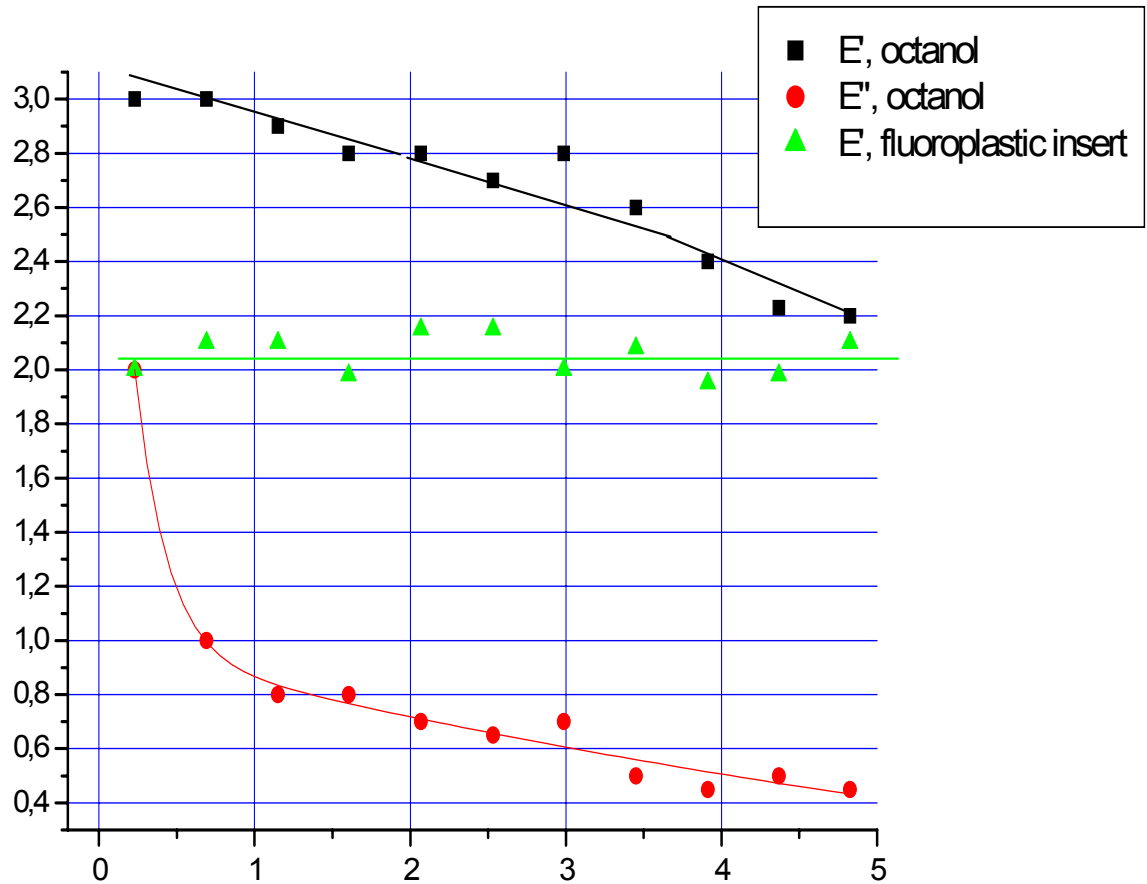

Figure 3. The real and imaginary components of relative permittivity of octanol at 25°C as a function of frequency (GHz).

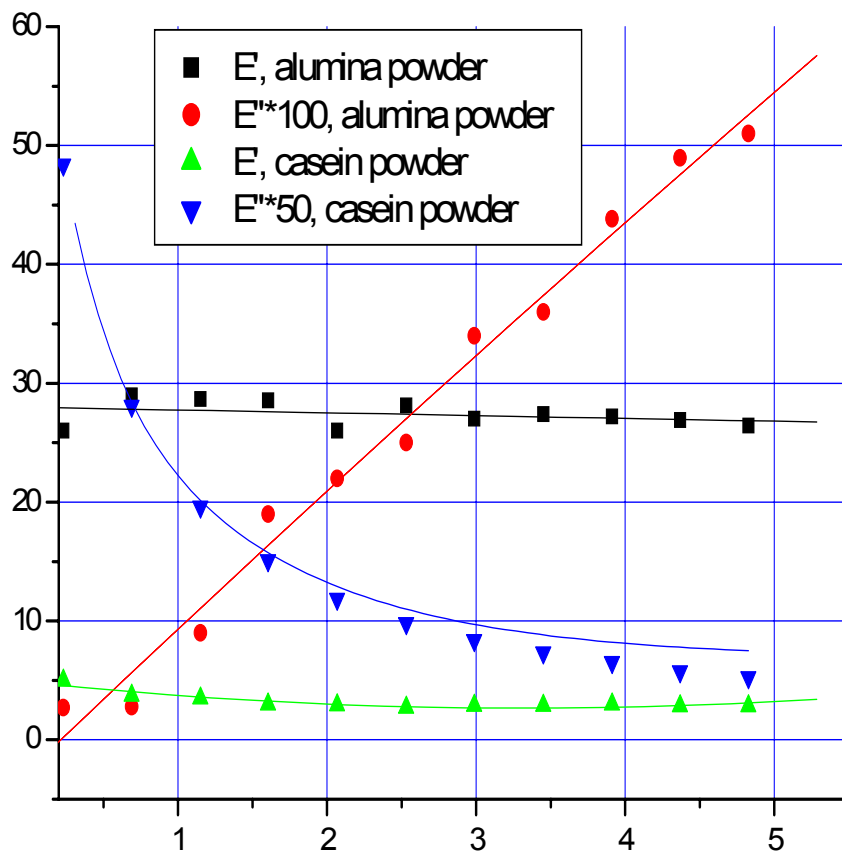

Figure 4. The real and imaginary components of relative permittivity of alumina powder (moisture 2.5 %) and casein powder (moisture 6 %) at 25°C as a function of frequency (GHz).

The presented set of curves displays, that the frequency of a pica of a dielectric relaxation for water adsorbed on surface of adamant is close to frequency of a pica for free water, the frequency of a pica of a dielectric relaxation for water in casein is on frequency about 200 MHz.

## Industrial spectrometers

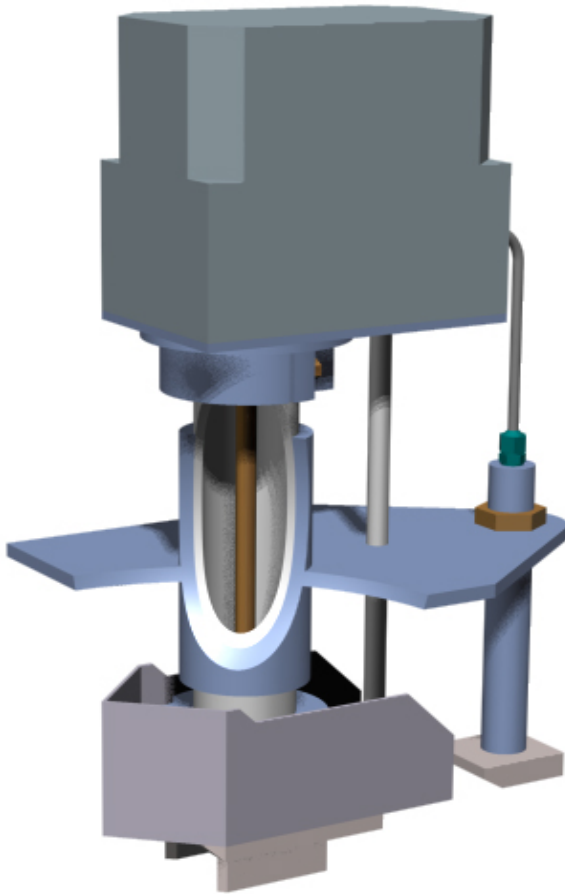

Fig. 5

conveyer belts is shown in Fig. 5.

The sensor is manufactured from extra strong alloys for operation with abrasives. For elimination of balling the device has self-acting system of keeping up high (up to 110 ° C) temperature of the sensor.

One modification of spectrometers intended for operation with materials on

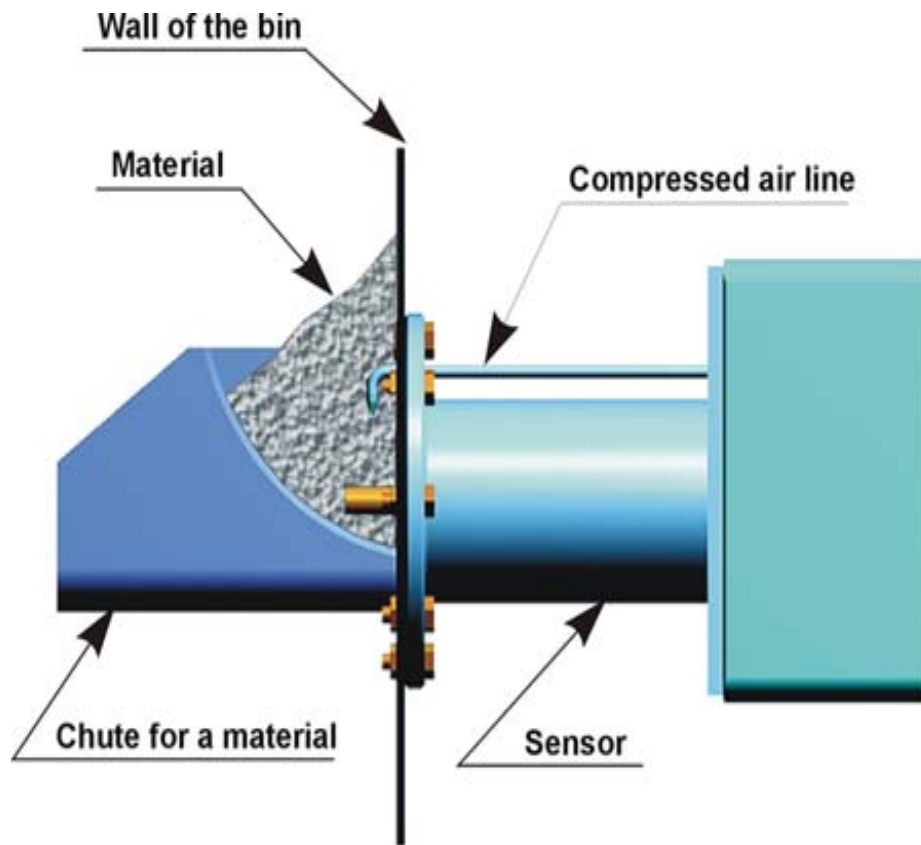

Fig. 6

In Fig. 6 a modification of spectrometers intended for operation with freely impinging materials (casein, dry milk, sand, soil, etc.) is shown.

## Conclusion

From these trials one can conclude that the new variant of microwave spectrometers provides adequate metrology for the complex dielectric permittivity, and that this approach is suitable for measurements of powders and other classes of materials.

Using the multi-frequency resonator spectrometer several spectra reflecting the processes of water loss and water bounding in such materials as talk, gelatine, sodium carbonate, sodium percarbonate and some other materials have been obtained.

The results of the research have proved the possibility of application of the multi-frequency resonator spectrometer for on-line dielectric measurements with the accuracy sufficient for control of various technological processes.